

## SAFETY TYPE OIL HEATERS

### Double Tube Heat Exchanger

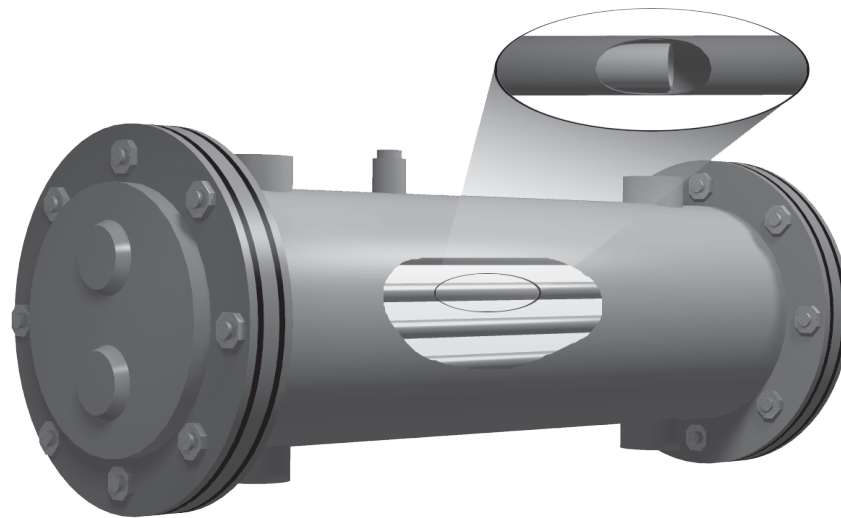

Safety Type Oil Heaters are water- or steam-to-oil double tube heat exchangers providing a reliable, efficient and safe method of heating oil for boiler plant operation. While used as a standard on hot water to oil heating applications, Safety Type Oil Heaters enhance steam to oil heating by permitting condensate to return to the boiler.

If there is a tube failure, the problems resulting from possible fuel oil contamination of the boiler and associated piping are minimized. On water to oil installations the high cost of providing pumps, expansion tanks, feeders, valves, etc. to provide an intermediate closed loop system is eliminated. On steam to oil installations the Safety Type Oil Heater avoids the substantial inefficiencies and problems involved with disposing of exchanger condensate that is prohibited by many environmental agencies because of the possibility of oil entering the disposal line system.

The Safety Type Oil Heater has a six pass design, and utilizes a tube within a tube construction. With oil in the inside tube and the heating medium in the shell and around the outside tube, as well as a highly efficient heat transfer fluid in the area between the tubes, double heat transfer is effected from the heating medium through the sealing fluid to the oil. Should a leak occur, the oil mixes only with the sealing fluid and is visually indicated at the rear of the safety chamber. Oil does not enter the boiler water.

Safety Type Oil Heaters are intended for installation on the discharge side of oil pumps. They have a steel shell and tube sheet, cast iron oil chamber, and 304 stainless steel oil tubes. The designed working pressure for both shell and tubes is 100 PSIG. Consult factory for higher capacities and pressures, and two (2) pass heaters for pump suction side installations or special configurations.

#### Suggested Specifications

Fuel oil heaters shall be of the Safety Type, six (6) pass, tube within a tube design with a capacity to heat \_\_\_\_\_ GPH of No. 6 fuel oil from \_\_\_\_\_°F to \_\_\_\_\_°F when supplied with (steam at \_\_\_\_\_ PSIG) (water at \_\_\_\_\_°F.) Heaters as furnished by Preferred Utilities Mfg. Corp., Danbury, CT, shall have 304 stainless steel tubes for oil, and shall comply with ASME requirements for 100 PSIG operation on both shell and tube sides.

#### Ordering Information

Safety Type Oil Heaters are custom made. Specify GPH capacity and heating capacity when ordering. Contact the factory for more information.

*Specifications subject to change without notice.*